

WEBSTER™

Engineering & Manufacturing Co., L.L.C.
619 Industrial Road, Winfield, Ks 67156

New Product Release -- CAM-NETICS II

This bulletin provides information on the new Cam-Netic II fuel cam provided by Webster Engineering & Manufacturing. This cam is available for all Webster Model JB and HD burners.



Components

The fuel cam is part of a “Single Point Positioning” or jackshaft linkage assembly that connects the modulation motor, air damper, FGR valve (if equipped) and fuel valve(s) to provide fuel-air-ratio control.

The jackshaft assembly consists of a shaft support bracket, a 3/4” jackshaft, drive arms on the jackshaft and cam(s) to drive the fuel valve(s). The cams will be used to drive the gas and/or oil fuel metering valve. Interconnecting linkage is used to connect the modulating motor to the jackshaft, air damper, fuel valves and FGR valve.

The fuel cams are mounted to the ends of the jackshaft bracket. The cam and adjusting screws are attached to and rotate with the jackshaft. A cam follower link follows the profile established by the adjusting screws, and modulates the fuel valve according to the position of the adjusting screws. A thin metal band is used between the screw and cam follower to provide a smooth profile. The adjusting screws are backed by

compressed nylon inserts, which provide a resistance to turning, locking the screws in place.

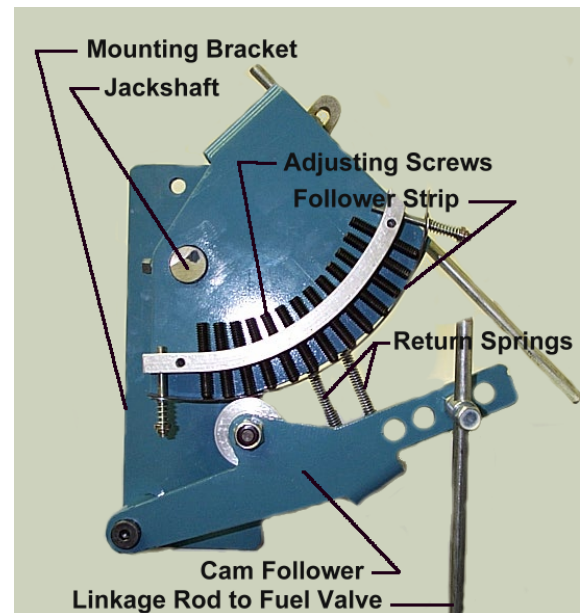

Initial Setup

The cam will have a coarse setup when it comes from the factory. Fine adjustments will be required to obtain the desired fuel-air-ratios and match the job specific conditions. Once the final cam and linkage positions have been set, they should be carefully documented so that the linkage can be returned to these settings if any component changes are made in the future.

The following general steps would be used to perform the setup of jackshaft and cam,

1. The modulating motor to jackshaft linkage must be adjusted so that the cam follower is between the first two screws at low fire and last two screws at high fire. This will allow all of the cam screws to be used for adjustment.

2. The remaining jackshaft linkage arm(s) are then connected and checked for correct low fire position and proper stroke. This is repeated for the air damper and FGR valve (if included).
3. Each cam linkage is connected to its fuel valve, adjusting the linkage to obtain the correct low fire position and stroke. There are multiple hole settings that can be used to change the stroke from the fuel cam.
4. Once the components are connected, the assembly should be checked for free and easy movement. The linkage end rods should not be binding and the cams should be easy to move.

Adjustments

The linkage setup, as well as the rough settings of the fuel and air controls, is done like any other burner. These initial adjustments use a combination of the fuel pressure regulator, linkage rod adjustments and position changes of the arms for slower or quicker opening of the valve.

WARNING

Only properly trained and qualified technicians can perform the fuel-air-ratio and initial light off adjustments of a new burner. Failure to follow this could result in injury or death.

The first step in the fuel air ratio setup is to determine the correct low fire and high fire positions of each valve. This may require multiple adjustments to match requirements for both gas and oil, and to match these fuels with the FGR settings. Gas is generally set first, and requires the gas pressure regulator to be set for high fire input before setting the valve positions. Oil is generally set to match the gas values, except in pressure atomizing burners, where the high and low fire is also limited by the oil nozzle capacities at low and high fire.

The basic linkage must also be set to provide a "rate of change" that is similar for the air and fuel valve. Often, the air damper can open quicker than the fuel valves, and can be slowed by

positioning the damper drive arm to be more parallel to the linkage.

Once the linkage has been set, the cam is adjusted to provide the exact settings desired combustion from low to high fire. Turning the adjusting screw in will increase fuel and turning it out will remove fuel. The screws are adjusted as a group, to develop a smooth profile from screw to screw.

WARNING

If the cam adjusting screw does not have resistance to turning, the cam should be replaced, as the screw may change position. Failure to change a defective cam may result in injury or death.

If the contour has a sharp rise in the cam screw profile, trying to open the fuel valve very quickly in the first few screws, the linkage should be readjusted to cause the air damper to open slower (make the jackshaft drive arm more parallel to the linkage). Likewise, the opposite contour can be corrected by speeding up the air damper drive. The final cam screw profile should be close to the profile of the cam with no abrupt changes.

CAUTION

Large changes from one adjusting screw to another will result in premature failure of the cam, and may prevent the burner from operating properly.

Maintenance

The cam and jackshaft should be visually checked on a daily or frequent basis for obvious problems, including jerky movement, loose parts and correct position of components.

On a monthly basis, the linkage and cams should be inspected for wear and loose parts.

Annually, the cam and linkage should be operated manually to check the movement and wear of all components and valves. Any worn parts should be replaced immediately.