



Webster Engineering & Manufacturing Co., L.L.C.
619 Industrial Road, Winfield, KS 67156

Operation, Maintenance & Installation Manual

SAVINGS METER OPTION

FOR TEMP A TRIM CONTROL



Manual Part No. 950077
August 2010
www.webster-engineering.com

TABLE OF CONTENTS

TABLE OF CONTENTS	i
CHAPTER 1: GENERAL.....	1
a. Inputs and Outputs.....	1
b. Components Provided.....	1
CHAPTER 2: INSTALLATION	2
CHAPTER 3: OPERATION	3
a. Operating the savings Meter	3
b. Description of Readings	3
c. Using the Averaging Function	4
CHAPTER 4: FUNCTION KEYS AND SCREENS	5
a. Flow Chart of Functions.....	5
b. Power-up Screen.....	6
c. Help Screen (F1).....	7
d. Current Reading (F3).....	8
e. Current Savings (F4).....	9
f. Average Savings (F5).....	10
g. Average Time Reset (F10)	11
h. Memory Card Missing Error.....	12
CHAPTER 5: CALIBRATION.....	13
a. Calibration Screen (F2)	13
b. Inlet Air Calibration (F3, in Calibrate Mode).....	15
c. Stack Temperature Calibration (F4, in Calibrate Mode).....	16
d. Factory Defaults (F5, in Calibration Mode)	17
CHAPTER 6: REFERENCE INFORMATION	19
a. Wiring Details for Savings Meter	19
b. General Wiring Diagram for Temp-A-Trim with Savings Meter	20
c. Horner Data Sheet for XLE Series Controllers	21

CHAPTER 1: GENERAL

The Savings Meter calculates the fuel and electrical savings from using the Temp A Trim (TAT) product on a boiler application. **If the TAT is not in the “RUN” mode, and controlling the speed of the combustion air motor, the Saving Meter will not calculate any savings.** The savings is given as a percent of the fuel and electric usage, based on the expected savings from the TAT operation. For complete information on the TAT savings, visit our web site at www.webster-engineering.com or contact your local Webster Engineering Representative.

The fuel savings comes from the TAT correction of the air density caused by changes in air temperature. Normally the burner will operate rich (low excess air) in hot temperatures and lean in cold temperatures. Without a combustion control, the burner is adjusted to work with low excess air rates (the most efficient operation) in hot temperatures, and then runs with high excess air in normal temperatures and very high excess air in cold temperatures. These high excess air rates reduce efficiency because that additional excess air will be heated to the stack temperature and lost to the environment. With TAT, the temperature is measured, and the fan speed is controlled to maintain the same mass flow at all temperatures, so the burner will operate at the most efficient excess air in hot, medium or cold air temperatures. The Savings Meter calculates this savings, and is displayed in real time and average savings over several days. The savings are based on a combustion air temperature range of 40 – 120 °F. If the alternate temperature range of 10 – 90 °F is selected in the TAT, then the savings could be slightly inaccurate if the unit is operating above 90 °F.

The electrical savings comes from the reduced speed of the fan and motor, as the TAT reduces speed to adjust for cooler air temperatures. Small reductions in fan speed can result in large savings as the energy saved is based on the fan speed to the third power.

The loss calculation is based on natural gas operation, and the ASME PTC 4.1 short form efficiency. While the savings will be similar for all fuels, the losses are about 4% to 5% higher for natural gas compared to oil. Likewise the efficiency of oil will be about 4% to 5% higher than the stated value.

a. Inputs and Outputs

- Power is provided by the 24 VDC power supply
- Combustion air temperature is read from the 4-20 ma output of the TAT board
- Stack Temperature is read from a “J” type thermocouple in the boiler stack
- Control “On-Off” is determined from the “Modulation Enable” output of the TAT

b. Components Provided

The Savings Meter consists of the following components;

Part No.	Description
778055	Savings Meter with keyboard & display
774109	Memory chip with program
S-25-24	Power Supply
	Thermocouple, J type (Length varies by boiler size)
	Other electrical components (relays, terminals as required per job)

CHAPTER 2: INSTALLATION

The Savings Meter is installed in the control panel from Webster Engineering. All panel wiring is also complete at the factory, as well as the programming of the control. The only installation work that needs to be completed in the field is the installation of the thermocouple.

The thermocouple should be mounted in the boiler outlet, breeching or stack, but upstream of any barometric dampers. The thermocouple end, which does the temperature measuring, should be in the flue gas stream to obtain an accurate temperature reading at all firing rates. It should not be located downstream of a baffle or other obstruction that would prevent flow from passing over the end of the thermocouple. It is recommended that if there is an economizer, the thermocouple should be mounted between the boiler and economizer to show the boiler operation, however it can be mounted downstream of the economizer. Normally a pipe nipple is welded to the stack to allow the installation of the thermocouple. If the stack has multiple walls, make sure that the insertion hole is through all of the walls.

“J” type thermocouple wire (not provided) must be used to wire the thermocouple to the control panel. It should be routed in a separate conduit to protect it from electrical interference. Do not route this wire in the same conduit as other higher voltage wiring, including 120 VAC as this can distort the weak signal. Also use care in routing the wire in the panel, to keep it away from other higher voltage lines.

The specific wiring related to the Savings Meter is shown in Reference Information at the end of this manual. These are the wiring connections made in the factory. A typical wiring diagram is also shown, and this indicates how the unit is wired to the TAT and burner controls.

CAUTION: EACH INSTALLATION IS UNIQUE AND CAN HAVE DIFFERENT CONTROLS AND WIRING REQUIREMENTS. REFER TO THE SPECIFIC WIRING DIAGRAM FOR YOUR BURNER WIRING.

CHAPTER 3: OPERATION

a. Operating the savings Meter

The Savings Meter is programmed and includes a memory card with the operating program. On initial power up, the display will say “CF Card missing, Webster p/n 774109 must be installed in meter (F7-Clear)”.

ON INITIAL POWER UP, PRESS THE “F7” KEY TO LOAD THE PROGRAM

This will load the program from memory, and allow it to run. Once the meter is operating, you can look at different information with the following screens,

- F1 = Help (lists different screens available)
 - F2 = Calibration of the stack thermocouple and inlet air sensor
 - F3 = Current readings
 - F4 = Current savings
 - F5 = Average savings
 - F10 = Reset the start time for averaging
-
- F2 = Calibration of the stack thermocouple and inlet air sensor
 - F3 following F2 = Calibration of inlet air temperature sensor
 - F4 following F3 = Calibration of stack temperature thermocouple
 - F5 following F2 = Restore factory default settings

Caution: Moving from the F2 screen to the F3, F4 or F5 screen will start a “Calibration process”. Move to the F1 screen to back out of calibration or press the ESC button.

Moving between the F1, F3, F4 and F5 screens can be done in any manner desired.

b. Description of Readings

The following information is available on the Savings Meter

1. Stack Temperature (°F) is a reading of the stack temperature of the boiler. It is measured by the thermocouple provided with the savings meter.
2. Inlet air temperature (°F) is read from the temperature sensor of the Temp A Trim product. The sensor is located near the air inlet damper of the burner, and should measure the temperature of the combustion air.
3. “Loss” is the flue gas loss that is a calculated value based on the difference in inlet air temperature and stack temperature for natural gas, using the PTC 4.1 calculation procedure.
4. Current Savings, Electrical. This is the expected electrical savings from the VFD and TAT operating under the current conditions. It is given as a % of electrical use. The electrical savings is based on the slower fan speed from the TAT control. The savings is directly tied to the combustion air temperature, where the speed will continue to drop to 40 °F, the lower end of the typical 40 – 120 °F control range of the TAT. If the TAT is set for the 10 – 90 °F range, the savings will be overstated if the unit operates above 90 °F.
5. Current Savings, Fuel. This is the expected fuel savings from the VFD and TAT operating under the current conditions. It is given as a % of fuel use. The fuel savings are based on a more constant fuel-air-ratio, or excess air rate. The calculations are based on the ASME PTC4.1 Simplified Efficiency Form. Like the electrical savings, if the lower operating temperature range is used on the TAT, and the burner operates above 90 °F, the fuel savings

calculation will indicate a higher savings, although this would normally be a minor difference. See the TAT Manual for more details on operating temperature ranges.

6. "Average Savings" is the F5 screen which shows the run time used to determine the average. The current averaging time is given in number of days, hours:minutes:seconds. This is the time that the TAT has been operating since the timer has been reset. All averages are based on this time, and are calculated over that period of time to provide a true monthly average, where the operator can set the start and stop times.
7. "Average Electric" is the average % savings from the date of the reset to the current time, based on the average electrical savings when the TAT has been operating. The electrical savings is from item #4, and the averaging time is from item #6.
8. "Average Fuel" is the average % fuel savings from the date of the reset to the current time, based on the average %fuel savings when the TAT has been operating. The fuel savings is from item #5, and the averaging time is from item #6.
9. "F10-Reset mm/dd/yy X". This defines the time reset used to the averaging function. The last reset date is given in the month/day/year schedule shown here. If the reset was done manually, an "M" is shown (after the date) and if it was an automatic reset (the unit will automatically reset after 57 days) an "A" will appear.
10. Mod Enable is an indicator light (small box in upper right hand corner) that is dark when the Temp A Trim is controlling.

c. Using the Averaging Function

The Averaging Function of the Savings Meter is designed to give the customer the ability to determine monthly savings. The start and stop time of the averaging is controlled by the user, where the F10 button will reset the time of averaging. The date of the last reset is given, along with the actual operating time of the TAT. It is possible that if the burner did not operate in the last month, there will be no savings. Likewise, if the TAT is in by-pass or not operating, there will be no operating time and no savings.

The difference between the "Run" time and the time since the last reset is a good indication of the usage rate of the boiler. In other words, if the "run" time shows 20 days, and it is 30 days since the last reset, then the usage rate is $20/30 = .67$ or 67% usage.

If the manual time reset is not used, the Savings Meter will automatically reset the time every 57 days.

CHAPTER 4: FUNCTION KEYS AND SCREENS

a. Flow Chart of Functions

The following chart shows the flow of different sequences in startup, information screens, and calibration. Each of these screens and functions are defined in more detail in the following pages.

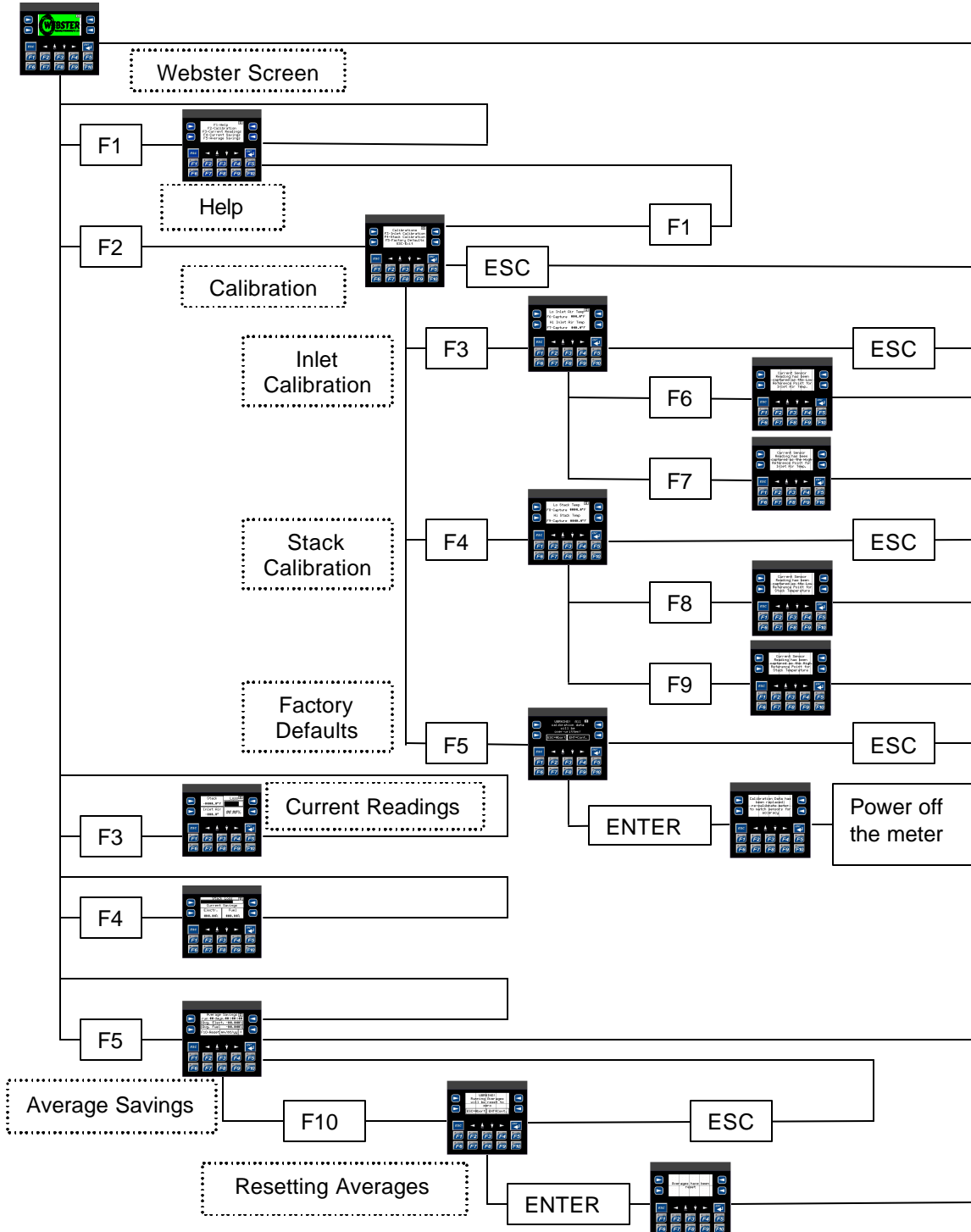

b. Power-up Screen



Figure 1 – Webster Logo Screen

When the efficiency meter first powers up, and any time the meter is reset, the above screen will be displayed.

The MOD ENABLE status indicator at upper right will be dark in its center when the Temp-A-Trim is actively controlling the fan speed. Savings and averages are only calculated when the MOD ENABLE status indicator is dark in the center.

c. Help Screen (F1)

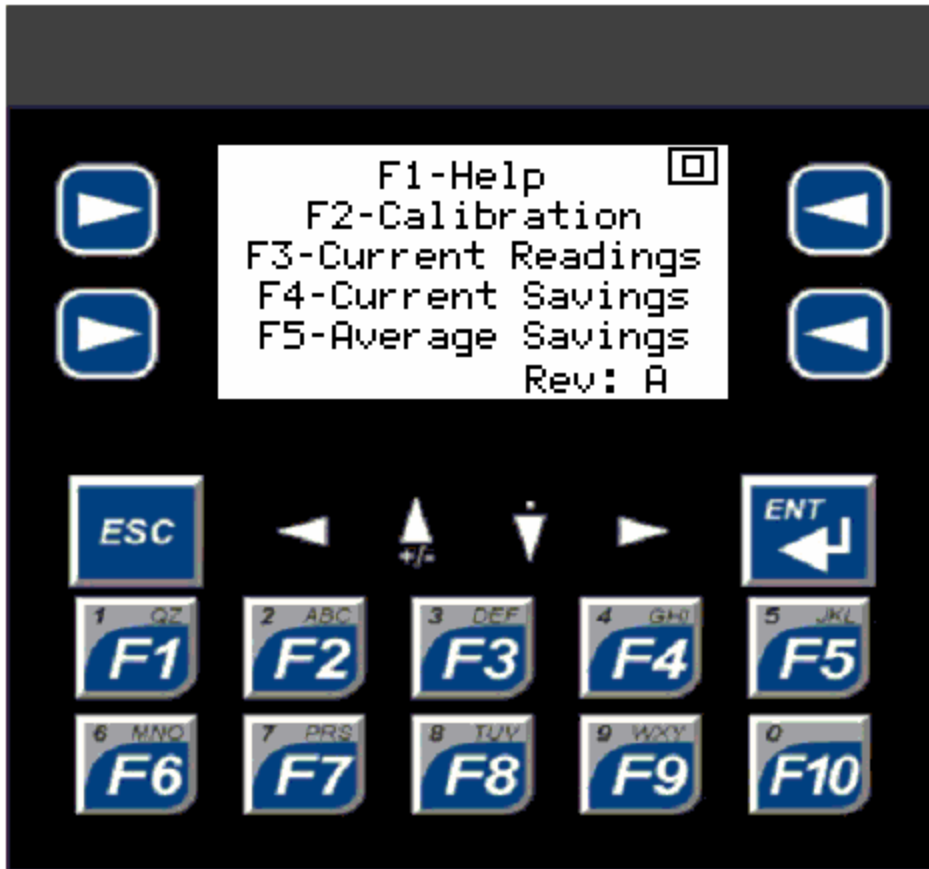

Figure 2 – Help Screen (F1)

Pressing the F1 key, when the Temp-A-Trim is controlling the fan motor, will result in the above screen being displayed, which describes how to access each of the main functions of the efficiency meter.

The MOD ENABLE status indicator at upper right will be dark in its center when the Temp-A-Trim is actively controlling the fan speed. Savings and averages are only calculated when the MOD ENABLE status indicator is dark in the center.

d. Current Reading (F3)

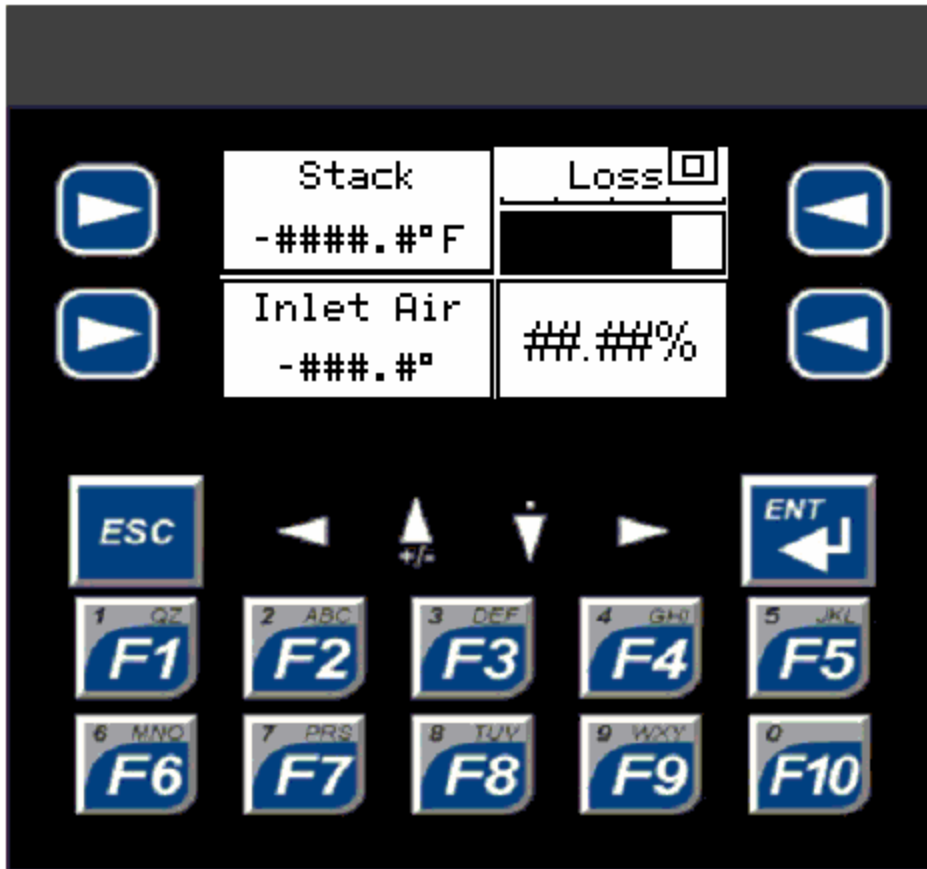

Figure 3 – Current Readings (F3)

Pressing the F3 key from any screen, other than the calibration screens, will display the Current Readings screen. This screen shows the current temperature readings for the stack and for inlet air, and the stack loss resulting from that temperature differential.

The MOD ENABLE status indicator at upper right will be dark in its center when the Temp-A-Trim is actively controlling the fan speed. Savings and averages are only calculated when the MOD ENABLE status indicator is dark in the center.

e. Current Savings (F4)

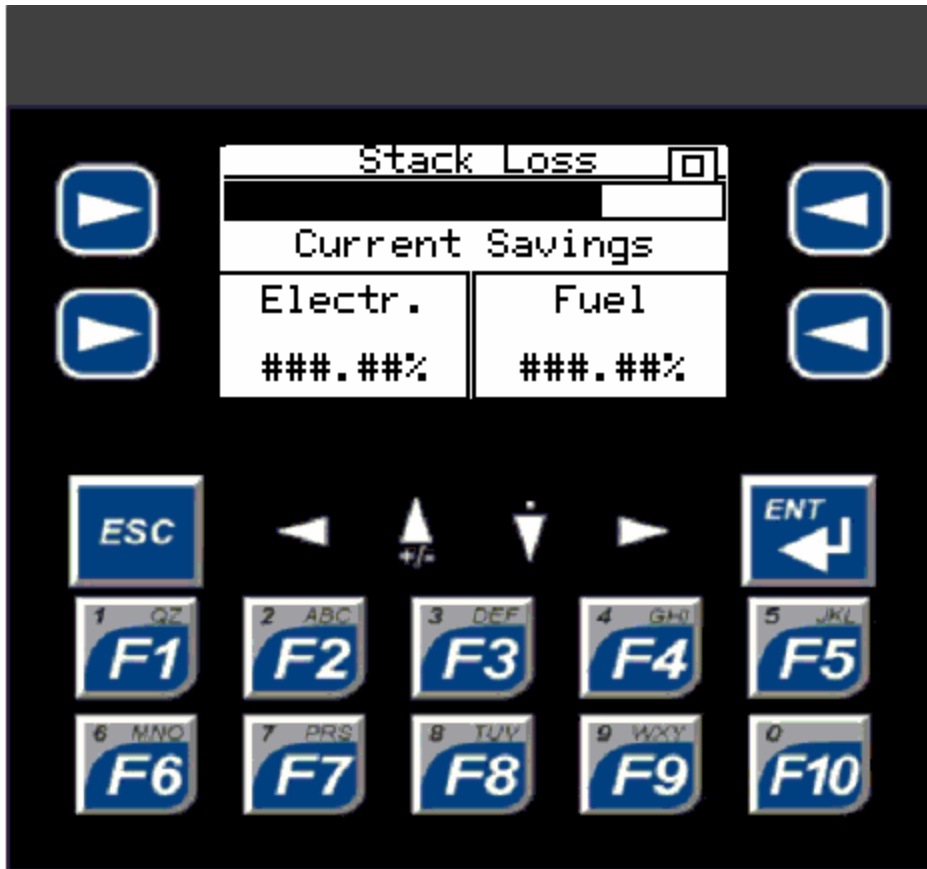

Figure 4 – Current Savings (F4)

Pressing the F4 key from any screen, other than the calibration screens, will display the current stack loss and the current % of electrical and fuel savings compared to the burner running uncontrolled by the Temp-A-Trim. Please note that these savings diminish the closer the inlet air temperature gets to 120°F, becoming zero at or above that temperature.

The MOD ENABLE status indicator at upper right will be dark in its center when the Temp-A-Trim is actively controlling the fan speed. Savings and averages are only calculated when the MOD ENABLE status indicator is dark in the center.

f. Average Savings (F5)

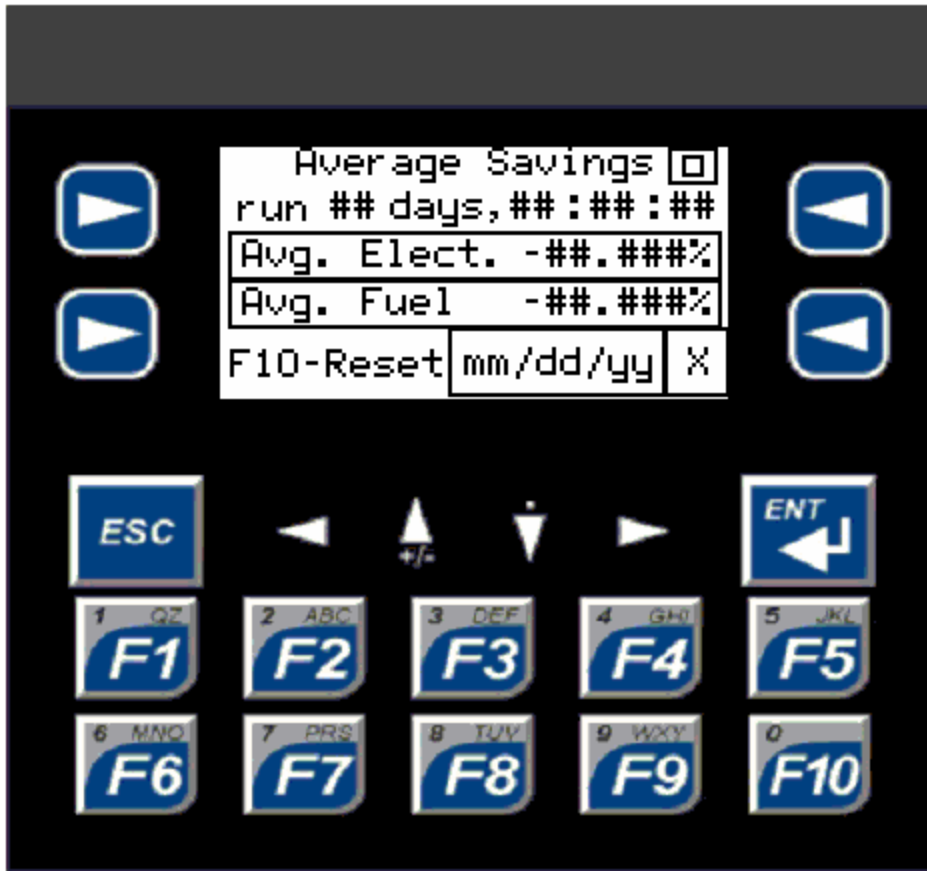

Figure 5 – Average Savings (F5)

Pressing the F5 key from any screen, other than the calibration screens, will display the average savings screen. This screen displays the following information:

Run time – the total time, since last reset, that the Temp-A-Trim has been controlling the burner. Note that this will, in most cases, be less than the total time since the last reset, as the burner will, in most cases, not be running continuously.

Avg. Elect. – the average electrical savings, in percent, as compared to the burner not being controlled by the Temp-A-Trim, over the number of samples given (average since last reset)

Avg. Fuel – the average fuel savings, in percent, as compared to the burner not being controlled by the Temp-A-Trim, over the number of samples given (average since last reset)

Last Reset Date – the date that the averages were last reset to zero

Last Reset Type – an “A” or an “M” will be displayed for whether the last reset was done automatically by the efficiency meter to prevent overflow of its internal registers (occurs if a manual reset is not performed for approximately 57 days of cumulative run time—time that the Temp-A-Trim is controlling the burner), or was done manually at the efficiency meter’s keypad, respectively

Pressing the F10 key while this screen is displayed will manually reset the averages to zero.

The MOD ENABLE status indicator at upper right will be dark in its center when the Temp-A-Trim is actively controlling the fan speed. Savings and averages are only calculated when the MOD ENABLE status indicator is dark in the center.

g. Average Time Reset (F10)

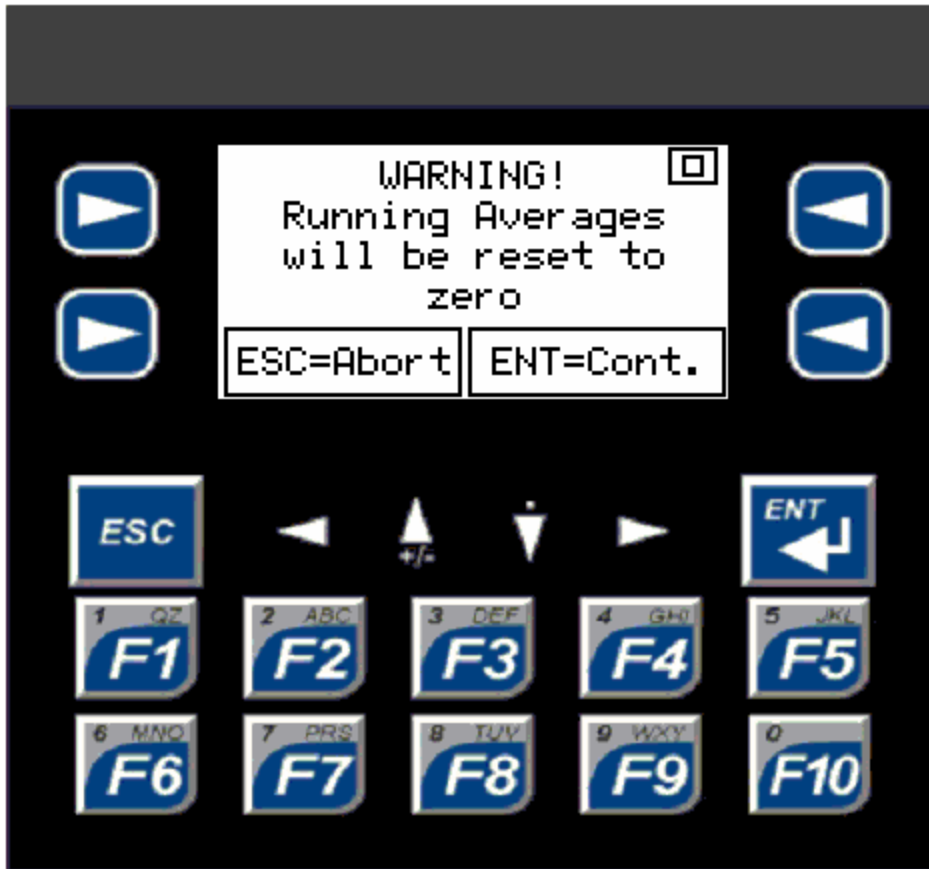

Figure 6--Average Reset Warning Message (F10 from Averages Screen)

Pressing F10 from the Averages Screen will cause the above warning message to be displayed. It is not possible, once the averages are reset, to view the lost data for the averages, therefore any logging or recording of the running averages must be done *prior* to resetting those averages.

To continue with the reset and over-write all running averages with zeroes, press the ENTER key.

To abort and leave the running averages as they are, press the ESC key.

Please note that memory in the efficiency meter is limited and the longest a running average can be held before it will automatically be reset by the meter is fifty-seven days.

The MOD ENABLE status indicator at upper right will be dark in its center when the Temp-A-Trim is actively controlling the fan speed. Savings and averages are only calculated when the MOD ENABLE status indicator is dark in the center.

h. Memory Card Missing Error



Figure 7 Compact Flash Card Missing Error Notice

In order for the Temp-A-Trim Efficiency Meter to operate, a pre-programmed Compact Flash card (Webster p/n 774109) must be installed in the controller. If this Compact Flash card is removed from the unit, the above screen will display and the meter will not operate. To clear this screen and return the meter to normal operation, install Webster p/n 774109 properly in the unit's memory slot, and then press and hold the F7 key until the screen displays the Webster logo. If the correct card has not been installed, however, this error screen will be re-displayed quickly after being cleared.

On initial power-up, it is also possible that this screen will display due to the fact that the controller is able to complete diagnostic tests on its memory slot before the Compact Flash card can complete testing of its own memory. Pressing the F7 key will clear the error message and allow the meter to begin normal operations.

CHAPTER 5: CALIBRATION

The Savings Meter can be calibrated to match the specifics of the inlet air and stack temperature sensors. General calibration numbers have been entered at the factory which should suffice for most cases, but this allows for specific unit calibration if required. To determine if this is required, compare the Savings Meter's current temperature readings with a calibrated sensor, or consult your company's quality procedure manual.

a. Calibration Screen (F2)



Figure 8 -- Calibration (F2)

Pressing the F2 key will access the calibration screen for the meter. From here, one can choose to calibrate the Inlet Air temperature readings, to calibrate the Stack temperature readings, or to reset the meter to its factory default settings. One may also return to the Help screen by pressing F1, or to the Webster logo screen by pressing ESC.

The MOD ENABLE status indicator at upper right will be dark in its center when the Temp-A-Trim is actively controlling the fan speed. Savings and averages are only calculated when the MOD ENABLE status indicator is dark in the center.

Please note that, when this screen is visible, the default actions of the F3, F4, and F5 buttons change from displaying data to calibrating the meter.

It is recommended to perform a calibration of both the Inlet Air readings and the Stack readings when the meter is installed, and any time thereafter that the meter is restored to factory defaults. Calibrations should be performed using an accurate temperature standard.

b. Inlet Air Calibration (F3, in Calibrate Mode)

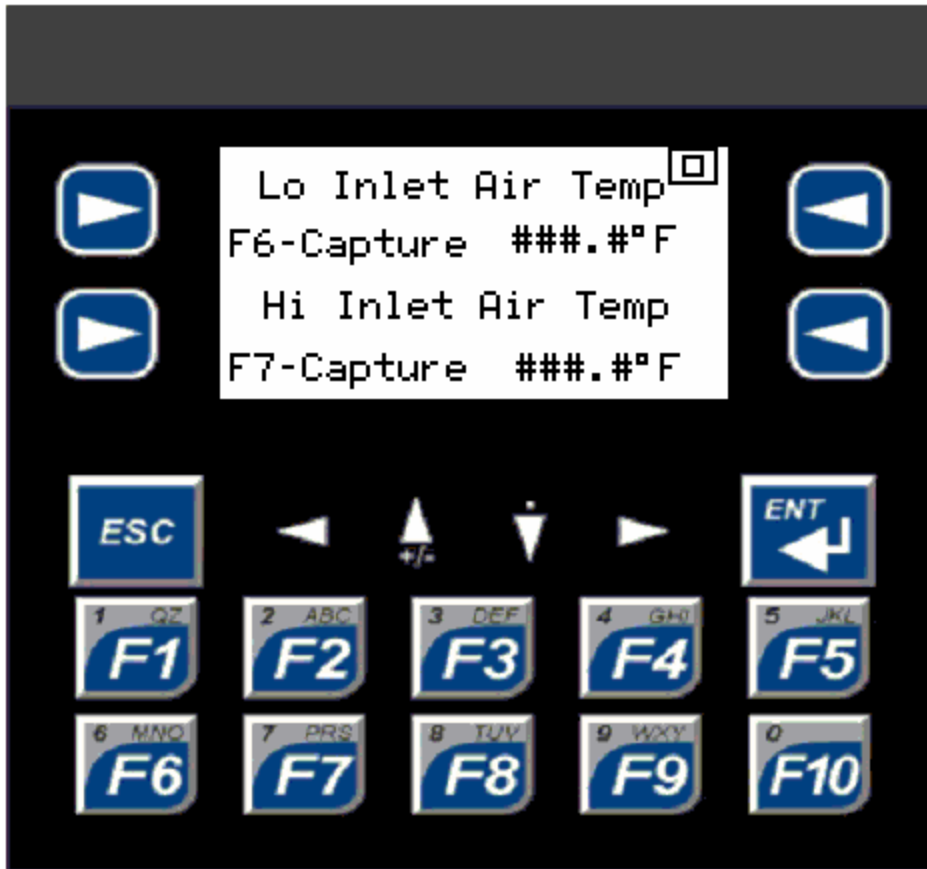

Figure 9 – Inlet Air Calibration (F3 from Calibration screen)

From the Calibration screen, press F3 for the Inlet Air Temperature. To calibrate the inlet air temperature sensor:

1. Place a known calibrated temperature sensor or thermometer in close proximity to the inlet air RTD sensor, and reduce the temperature around both sensors to a point at or above 40°F (5°C).
2. When the temperature has stabilized at or near 40°F, press the F6 key on the efficiency meter to capture the reading being transmitted from the Temp-A-Trim, then enter the value displayed by the known calibrated sensor or thermometer into the meter using the ? , ? , ? , ? , and ENTER keys. This may be repeated as often as necessary to establish a known reference point for the low end of the temperature range of the Temp-A-Trim board.
3. After calibrating the low end of the temperature range, raise the temperature around both sensors to a point at or below 120°F (50°C).
4. When the temperature has stabilized at or near 120°F, press the F7 key on the efficiency meter to capture the reading being transmitted from the Temp-A-Trim, then enter the value displayed by the known calibrated sensor or thermometer into the meter using the ? , ? , ? , ? , and ENTER keys. This may be repeated as often as necessary to establish a known reference point for the high end of the temperature range of the Temp-A-Trim board.
5. Do not decrease temperature below 40°F or above 120°F during calibration, as this can yield inconsistent results from under-ranging or over-ranging the Temp-A-Trim's temperature range.

c. Stack Temperature Calibration (F4, in Calibrate Mode)

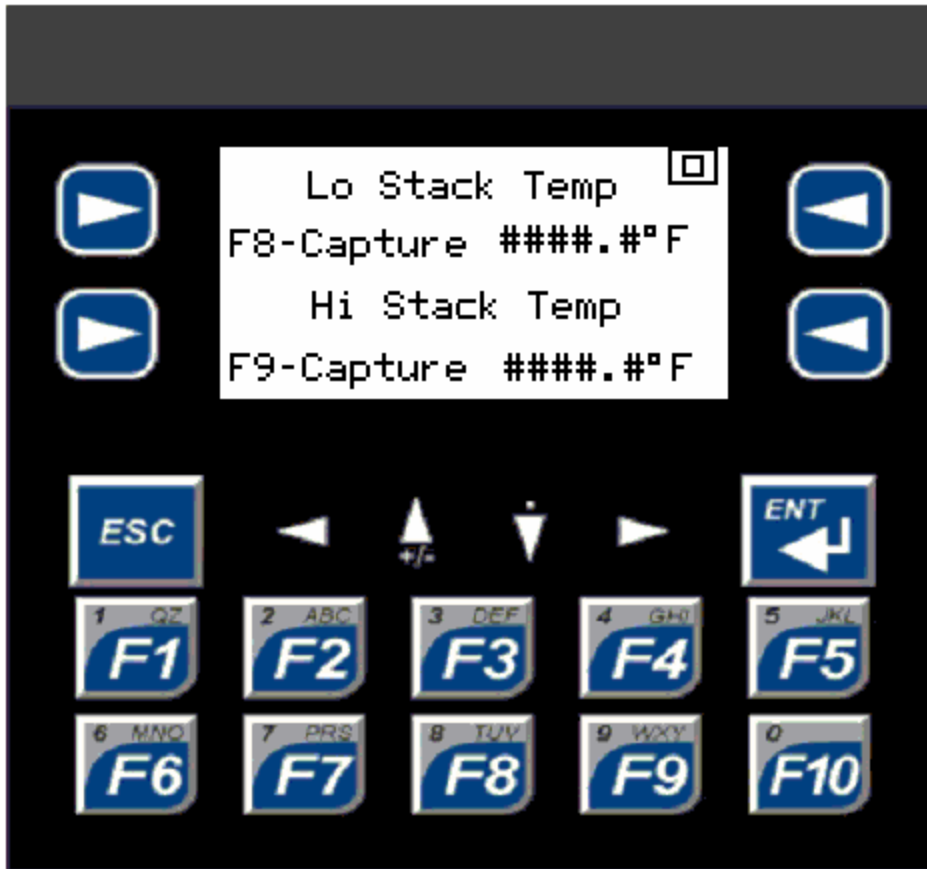

Figure 10 – Stack Calibration (F4 from Calibration screen)

From the Calibration screen, press F4 for the Stack Temperature. To calibrate the stack temperature sensor:

1. Place a known calibrated temperature sensor or thermometer in close proximity to the J thermocouple for the stack, and reduce the temperature around both sensors to a point at or above 32°F (0°C).
2. When the temperature has stabilized at or near 32°F, press the F8 key on the efficiency meter to capture the reading being transmitted from the Temp-A-Trim, then enter the value displayed by the known calibrated sensor or thermometer into the meter using the \uparrow , \downarrow , \leftarrow , \rightarrow , and ENTER keys. This may be repeated as often as necessary to establish a known reference point for the low end of the temperature range of the J thermocouple.
3. After calibrating the low end of the temperature range, raise the temperature around both sensors to a point at or below 600°F (315°C).
4. When the temperature has stabilized at or near 600°F, press the F7 key on the efficiency meter to capture the reading being transmitted from the Temp-A-Trim, then enter the value displayed by the known calibrated sensor or thermometer into the meter using the \uparrow , \downarrow , \leftarrow , \rightarrow , and ENTER keys. This may be repeated as often as necessary to establish a known reference point for the high end of the temperature range of the J thermocouple.

d. Factory Defaults (F5, in Calibration Mode)



Figure 11 – Factory Defaults (F5 from Calibration screen)

Pressing F5 at the Calibration screen will ask for restoring all calibrations settings in the meter to their factory default values, and will produce the above warning message. To abort and back out of this message with all calibration data intact, press the ESC key. To over-write all calibration data with the factory defaults, press the ENTER key.

The MOD ENABLE status indicator at upper right will be dark in its center when the Temp-A-Trim is actively controlling the fan speed. Savings and averages are only calculated when the MOD ENABLE status indicator is dark in the center.



Figure 12 -- Factory Defaults Restored Warning

Pressing the ENTER key from the Factory Defaults warning screen will replace all calibration data in the meter with the factory defaults, and will lock the display on the above warning message. The only way to clear the display from this message is to power-cycle the meter (remove 24VDC power from the meter by unplugging the black plug on the bottom of the meter, then restore power by plugging the black plug back into the meter). The meter is deliberately designed this way so that an accidental over-write of calibration data does not go un-noticed.

While the meter will run with factory default data, greatest accuracy is obtained only by calibrating the meter to match the sensors and conditions in its field installation. Therefore, it is recommended that any time the meter is reset to factory default data, it should be re-calibrated with standards of known accuracy to match its sensors as closely as possible.

The MOD ENABLE status indicator at upper right will be dark in its center when the Temp-A-Trim is actively controlling the fan speed. Savings and averages are only calculated when the MOD ENABLE status indicator is dark in the center.

b. General Wiring Diagram for Temp-A-Trim with Savings Meter

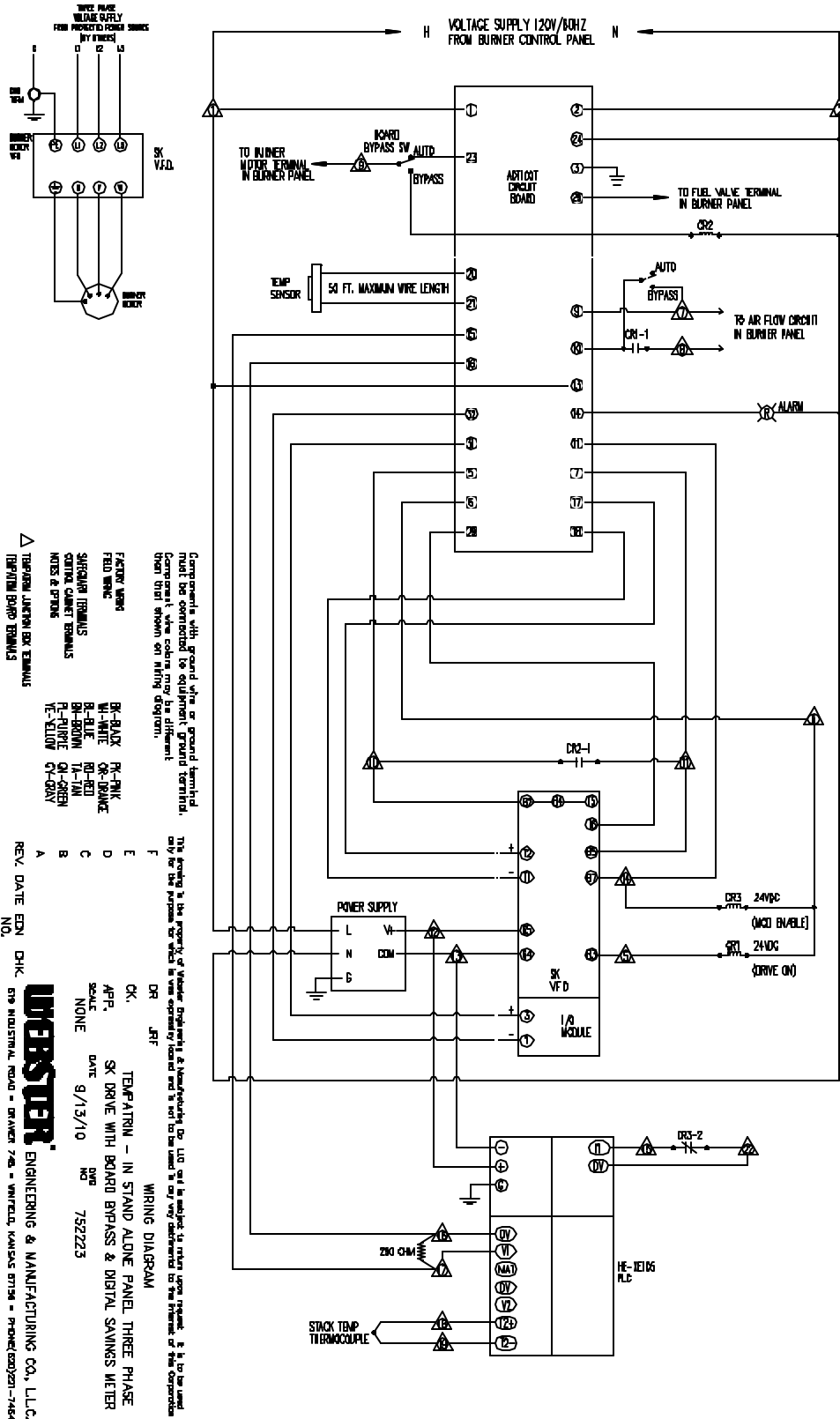

c. Horner Data Sheet for XLE Series Controllers

MAN0810-07
Specifications / Installation

4 April 2007

PAGE 1
HE-XE105



XLE OCS Model: HE-XE105
12 Digital DC Inputs / 12 Digital DC Outputs
2 Analog Inputs (High Resolution) / 2 Analog Outputs
 (for firmware version 11.82 and later)

Want More Information?
 To download the XLE User Manual
 (MAN0805), refer to *Technical Support* in this document.

Digital DC Inputs		Digital DC Outputs	
Inputs per Module	12 including 4 configurable HSC inputs	Outputs per Module	12 including 2 configurable PWM outputs
Commons per Module	1	Commons per Module	1
Input Voltage Range	12 VDC / 24 VDC	Output Type	Sourcing / 10 K Pull-Down
Absolute Max. Voltage	35 VDC Max.	Absolute Max. Voltage	28 VDC Max.
Input Impedance	10 kΩ	Output Protection	Short Circuit
Input Current	Positive Logic: 0.8 mA Negative Logic: -1.6 mA	Max. Output Current per point	0.5 A
Upper Threshold	0.8 mA	Max. Total Current	4 A Continuous
Lower Threshold	0.3 mA	Max. Output Supply Voltage	30 VDC
Max Upper Threshold	8 VDC	Minimum Output Supply Voltage	10 VDC
Min Lower Threshold	3 VDC	Max. Voltage Drop at Rated Current	0.25 VDC
OFF to ON Response	1 ms	Max. Inrush Current	650 mA per channel
ON to OFF Response	1 ms	Min. Load	None
HSC Max. Switching Rate	10 kHz Totalizer/Pulse, Edges 5 kHz Frequency/Pulse, Width 2.5 kHz Quadrature	OFF to ON Response	1 ms
		ON to OFF Response	1 ms
		Output Characteristics	Current Sourcing (Pos logic)
Analog Inputs / High Resolution			
Number of Channels	2	Thermocouple	Temperature Range
Input Ranges (Selectable)	0 - 10 VDC 0 - 20 mA 4 - 20 mA 100mV PT100 RTD, and J, K, N, T, E, R, S, B Thermocouples	B / R / S	2912°F to 32.0°F (1600°C to 0°C)
		E	1652°F to -328°F (900°C to -200°C)
		T	752.0°F to -400.0°F (400°C to -240°C)
Safe input voltage range	10 VDC: -0.5 V to +15 V 20 mA: -0.5 V to +6 V RTD / T/C: ±24 VDC	J	1382.0°F to -346.0°F (750°C to -210°C)
Nominal Resolution	10V, 20mA, 100mV: 14 Bits RTD, Thermocouple: 16 Bits	Thermocouple Common Mode Range	
		±10V	
Input Impedance (Clamped @ -0.5 VDC to 12 VDC)	Current Mode: 100 Ω, 35mA Max. Continuous Voltage Mode: 500 kΩ, 35mA Max. Continuous	Converter Type	Delta Sigma
		Max. Error at 25°C (*excluding zero)	*4-20 mA ±0.10% *0-20 mA ±0.10% *0-10 VDC ±0.10% RTD (PT100) ±1.0 °C 0-100 mV ±0.05%
%AI full scale	10 V, 20 mA, 100 mV: 32,000 counts full scale. RTD / T/C: 20 counts / °C	Max Thermocouple Error (After Warm Up Time of One Hour)	±0.2% (±0.3% below -100°C)
Max. Over-Current	35 mA	Conversion Speed, Both Channels Converted	10V, 20mA, 100mV: 30 Times/Second RTD, Thermocouple: 7.5 Times/Second
Open Thermocouple Detect Current	50 nA	Conversion Time per Channel	10V, 20mA, 100mV: 16.7mS RTD, Thermocouple: 66.7mS
Number of Channels	2	Required Power (Steady State)	130 mA @ 24 VDC
		Required Power (Inrush)	30 A for 1 ms @ 24 VDC
Output Ranges	0-10 VDC, 0-20 mA	Primary Power Range	10 - 30 VDC
Nominal Resolution	12 Bits	Operating Temperature	0° to 50° Celsius
Update rate	Once per PLC scan	Storage Temperature	14 to 140°F (-10 to 60°C)
Minimum 10 V load	1 kΩ	Relative Humidity	5 to 95% Non-condensing
Maximum 20 mA load	500 Ω	Filtering	15Hz hash (noise) filter 1-128 scan digital running average filter
Analog Outputs; Output Points Required	2	Terminal Type	Screw Type 5 mm Removable
Maximum Error at 25°C (excluding zero)	0.1%	Weight	12.5 oz. (354.36)
Additional error for temperatures other than 25°C	0.01% / °C	CE	See Compliance Table at http://www.heag.com/Support/compliance.htm
		UL	

6 Digital Filtering for Analog Inputs

The digital filter is updated once per conversion. It is an "IIR" running average filter that emulates a simple RC filter. The equivalent time constant is determined by the Filter Constant and the sum of the conversion times for the two channels. The Filter Constant determines the weight given to the most recent conversion. The following table lists the equivalent time constant for the three possible total conversion times, which are dependent upon the two input mode selections. This filter delay is in addition to the PLC scan delay.

Filter Constant	Total Conversion Time in Seconds		
	0.03	0.09	0.13
0*	0.03*	0.09*	0.13*
1	0.07	0.18	0.27
2	0.13	0.35	0.53
3	0.27	0.71	1.07
4	0.53	1.41	2.13
5	1.07	2.83	4.27
6	2.14	5.65	8.54
7	4.28	11.30	17.08

* No filter delay, reading is unfiltered conversion value

7 Thermocouple Grounding Schemes

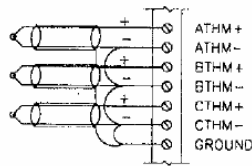

Ungrounded Thermocouples
Alternate Shield Connection for Ungrounded Thermocouples.

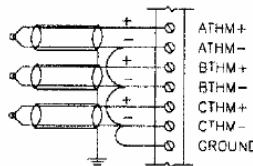

Ungrounded Thermocouples
Preferred Shield Connection for Ungrounded Thermocouples.

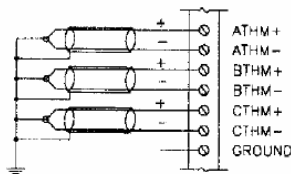

Grounded Thermocouples
Field Ground Potential Less Than Seven Volts AC
Typical Shield Connection for Grounded Thermocouples

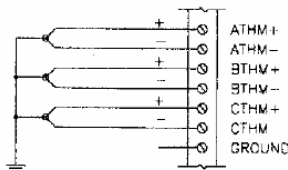

Grounded Thermocouples
Field Ground Potential Less Than Seven Volts AC
Shields Connected at One End Only May be Used to Reduce Noise
Grounded Thermocouples May Use the Ungrounded Thermocouple Shield Connections if the Shield is not Grounded at the Field End

8 Safety

When found on the product, the following symbols specify:

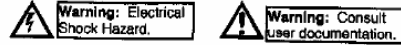

WARNING: To avoid the risk of electric shock or burns, always connect the safety (or earth) ground before making any other connections.
WARNING: To reduce the risk of fire, electrical shock, or physical injury it is strongly recommended to fuse the voltage measurement inputs. Be sure to locate fuses as close to the source as possible.
WARNING: Replace fuse with the same type and rating to provide protection against risk of fire and shock hazards.
WARNING: In the event of repeated failure, do not replace the fuse again as a repeated failure indicates a defective condition that will not clear by replacing the fuse.
WARNING: Only qualified electrical personnel familiar with the construction and operation of this equipment and the hazards involved should install, adjust, operate, or service this equipment. Read and understand this manual and other applicable manuals in their entirety before proceeding. Failure to observe this precaution could result in severe bodily injury or loss of life.

*All applicable codes and standards need to be followed in the installation of this product.

- *Adhere to the following safety precautions whenever any type of connection is made to the module:
- *Connect the safety (earth) ground on the power connector first before making any other connections.
- *When connecting to electric circuits or pulse-initiating equipment, open their related breakers.
- *Do not make connections to live power lines.
- *Make connections to the module first; then connect to the circuit to be monitored.
- *Route power wires in a safe manner in accordance with good practice and local codes.
- *Wear proper personal protective equipment including safety glasses and insulated gloves when making connections to power circuits.
- *Ensure hands, shoes, and floor are dry before making any connection to a power line.
- *Make sure the unit is turned OFF before making connection to terminals.
- *Make sure all circuits are de-energized before making connections.
- *Before each use, inspect all cables for breaks or cracks in the insulation. Replace immediately if defective.

9 Technical Support

For assistance and manual updates, contact Technical Support at the following locations:

North America:
(317) 918-4274
www.heag.com
email: techsupport@heag.com

Europe:
(+) 353-21-4321-266
www.horner-ag.com
email: techsupport@hornerid.ie