



# Model HDRMB Ultra Low NOx Burners

Typical Sizes & Dimensional Data

9 ppm NOx - 100 to 950 HP

Burner selections and dimensions are based on 9 ppm NOx performance firing natural gas at the rated Boiler HP and given furnace pressure. The combustion air temperature is assumed to be 100° F, stack temperature 450° F, and altitude to 1000 feet.

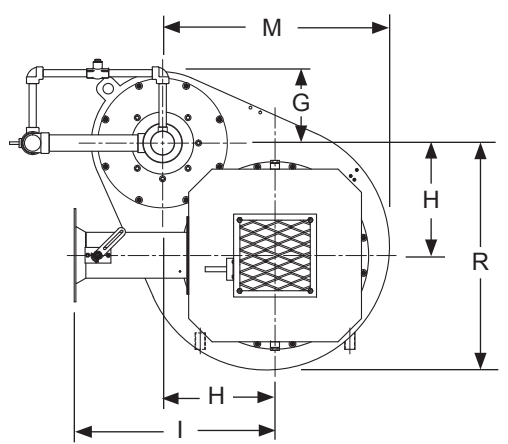
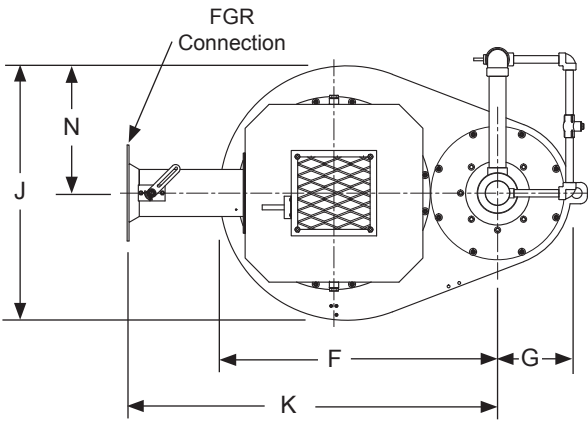
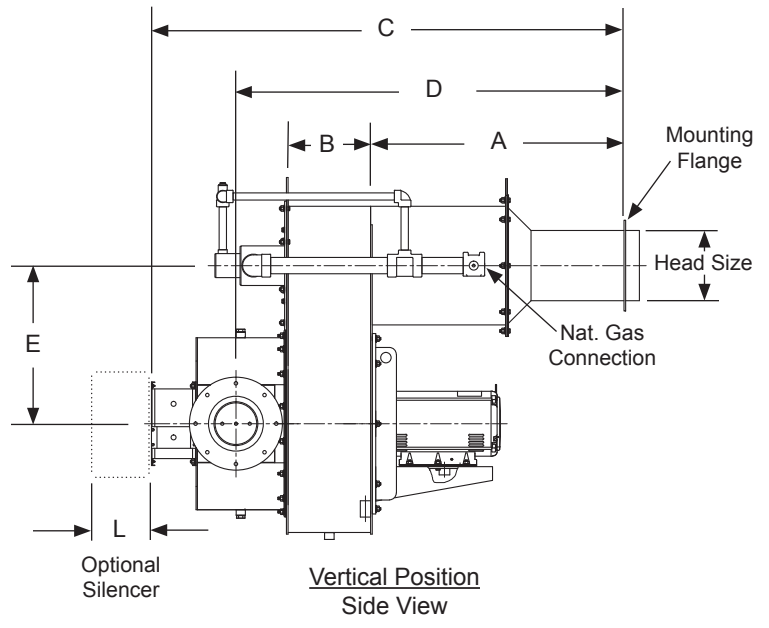
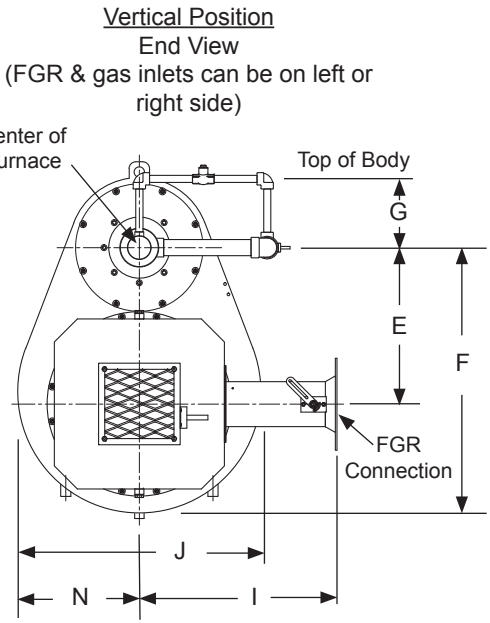

45° Slant Position  
End View - Slant Right Shown  
(FGR & Gas inlets can be on left or right side)  
Slant left available

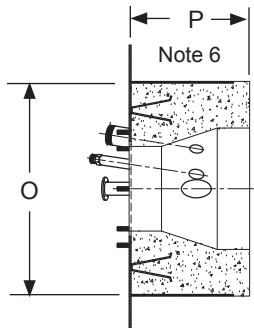

Refractory  
(Mounting plate is critical to burner performance and must be provided by Webster Engineering)

Graphics and dimensions are generic and should not be used for construction. Job specific options and design upgrades can change details. Contact Webster to verify critical dimensions.

**Typical Sizes and Dimensions (diagrams on page one)**

Boiler HP	Normal furnace press w/o FGR	Combustion head size (diameter)	FGR duct size	Motor HP	Housing size	Head length	Housing width	Overall length	Length to FGR flange	Height to FGR flange	Center burner to bottom	Center burner to top	Offset damper at 45°	Width to FGR flange	Housing width	Width to FGR flange - horizontal	Depth optional silencer	Slant right width	Slant right height	Width, left side of housing	Minimum refractory OD	Refractory length
						A	B	C	D	E	F	G	H	I	J	K	L	M	R	N	O	P
100	2.5	8	8	10	HDRMB5	29.5	10.9	59.9	47.6	21.8	35.0	10.0	15.4	22.8	30.5	44.5	9.3	30.6	30.6	15.3	20.0	13.5
125	2.6	9	8	15		33.1	10.9	63.5	51.3	21.8	35.0	10.0	15.4	22.8	30.5	44.5	11.3	30.6	30.6	15.3	21.5	14.2
150	2.8	10	8	15		32.3	10.9	62.7	50.4	21.8	35.0	10.0	15.4	22.8	30.5	44.5	11.3	30.6	30.6	15.3	23.0	14.9
200	3.0	11	10	20		32.9	10.9	68.3	58.5	21.8	35.0	10.0	15.4	30.5	30.5	52.3	8.0	30.6	30.6	15.3	24.5	15.5
225	3.1	12	10	25		34.8	10.9	70.2	55.4	21.8	35.0	10.0	15.4	30.5	30.5	52.3	8.0	30.6	30.6	15.3	26.0	16.3
250	3.3	12	10	30		34.8	10.9	70.2	55.4	21.8	35.0	10.0	15.4	30.5	30.5	52.3	8.0	30.6	30.6	15.3	26.0	16.3
275	3.4	13	12	30	HDRMB7	35.9	12.5	72.9	58.2	23.0	39.1	10.3	16.3	30.5	35.8	58.5	10.0	34.1	34.1	17.9	27.5	17.0
300	3.5	14	12	30		35.0	12.5	72.0	57.3	23.0	39.1	10.3	16.3	30.5	35.8	58.5	10.0	34.1	34.1	17.9	29.0	17.6
350	3.8	15	12	40		37.1	12.5	74.1	59.3	23.0	39.1	10.3	16.3	30.5	35.8	58.5	10.0	34.1	34.1	17.9	30.5	18.3
400	4.0	16	14	40		38.2	12.5	80.2	62.9	23.0	39.1	10.3	16.3	33.0	35.8	56.0	10.0	34.1	34.1	17.9	32.0	19.0
450	4.3	17	14	50		37.3	12.5	79.3	62.1	23.0	39.1	10.3	16.3	33.0	35.8	56.0	14.0	34.1	34.1	17.9	33.5	19.7
500	4.5	18	14	50		HDRMB9	43.7	14.5	87.7	70.0	30.4	51.6	13.8	21.5	32.6	42.4	63.0	14.0	44.6	40.8	18.5	35.0
550	4.8	19	14	50	43.8		14.5	91.8	69.1	30.4	51.6	13.8	21.5	32.6	42.4	63.0	14.0	44.6	40.8	18.5	36.5	21.1
600	5.0	20	16	50	41.9		14.5	90.9	70.8	30.4	51.6	13.8	21.5	35.1	42.4	65.5	14.0	44.6	40.8	18.5	36.5	21.8
650	5.3	20	16	75	41.9		14.5	90.9	70.8	30.4	51.6	13.8	21.5	35.1	42.4	65.5	16.0	44.6	40.8	18.5	38.0	21.8
700	5.5	21	16	75	45.0		14.5	94.0	73.8	30.4	51.6	13.8	21.5	35.1	42.4	65.5	16.0	44.6	40.8	18.5	38.5	22.5
750	5.8	22	18	100	HDRMB11		46.2	19.5	106.2	81.5	35.0	60.1	13.5	24.7	36.3	50.5	71.6	16.0	52.0	48.0	22.2	41.0
800	6.0	23	18	100		45.3	19.5	105.3	80.5	35.0	60.1	13.5	24.7	36.3	50.5	71.6	16.0	52.0	48.0	22.2	42.5	23.8
900	6.5	24	18	100		46.5	19.5	106.5	81.8	35.0	60.1	13.5	24.7	36.3	50.5	71.6	16.0	52.0	48.0	22.2	44.0	24.5
950	6.8	24	18	100		46.5	19.5	106.5	81.8	35.0	60.1	13.5	24.7	36.3	50.5	71.6	16.0	52.0	48.0	22.2	44.0	24.5

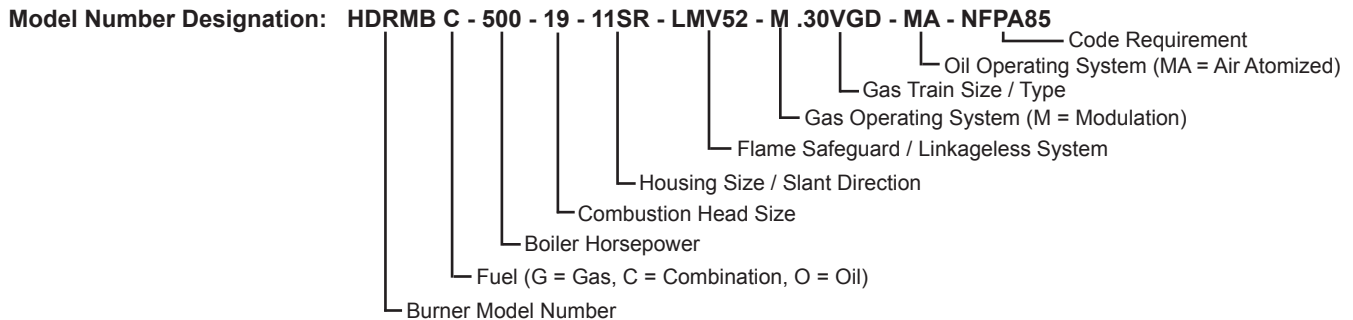

**Notes:**

1. Higher temperatures, altitude or furnace pressures may require a larger burner size to meet capacity and NOx performance.
2. Lower temperatures, altitude, furnace pressures, or higher NOx requirements, may allow for selection of a smaller burner size to meet capacity and NOx performance.
3. Furnace size is critical for the HDRMB application, and may require other conditions, including additional refractory or reduced rates.
4. Air inlet silencers are optional equipment for burners using the HDRMB5 and HDRMB7 housings. Air inlet silencers are standard for burners using the HDRMB9 and HDRMB11 housings. Optional silencers are available for all units.
5. Oil piping, control panels and related hardware are not shown in the sketches on page one, but should be considered in the final installations.
6. Refractory length "P" is fixed by design. Flange location can be modified to allow end position to be flush with water tube front wall or short of corrugations in a firetube. "O" dimension can be larger to fit opening.
7. FGR valve is integral to piping shown for 14" and smaller. 16" and larger valves are wafer style mounted on flange shown.