



Model JB3 Forced Draft Burners

Specification & Dimensional Data

(1400 - 12,600 MBH Input)

Fuels Burned and Control Systems

- Natural Gas, Propane, Digester or Mixed Gases
- Light #2 through Heavy #6 Fuel Oil
- Modulating Control System - Micro Modulation or Linkage
- Control Circuit Requires 120 vac, 60 Hz, Single Phase Voltage Supply

Check appropriate box to indicated selected version. (Dimensions are +/- 1/4 inch)

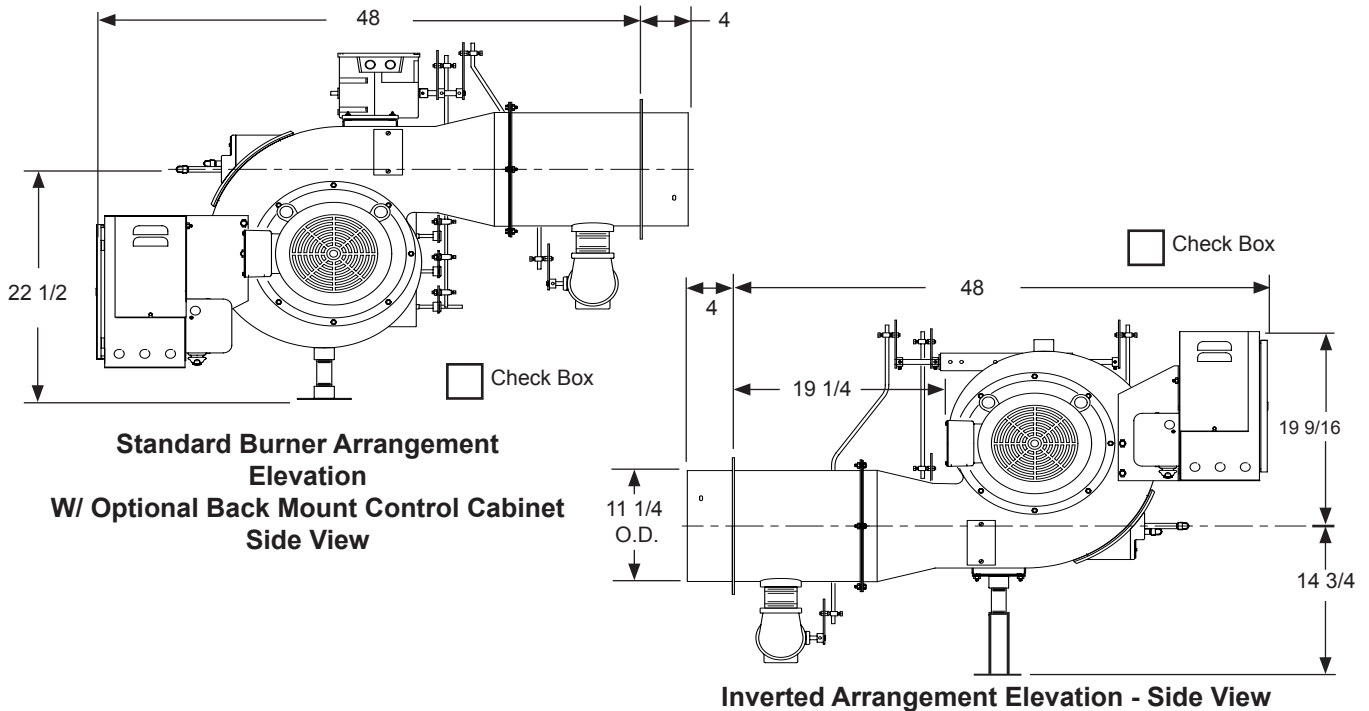
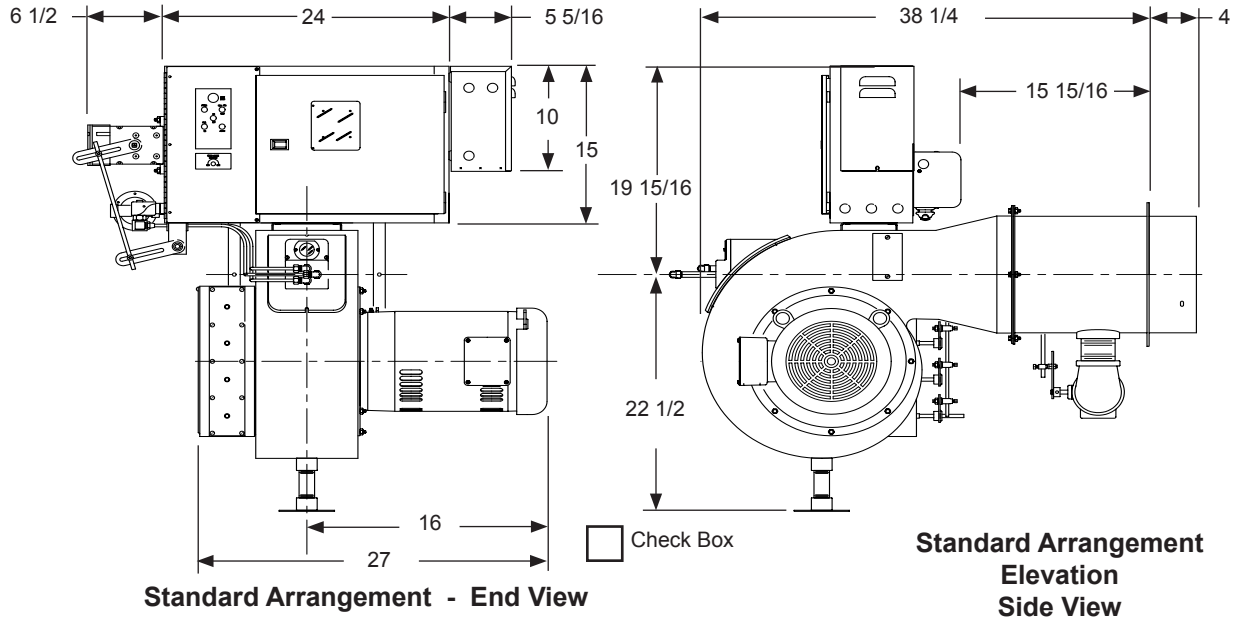

Model JB3 burners are listed by Underwriters Laboratories, Inc. (UL / ULC). Also by the State of Massachusetts Fire Marshal, City of New York Board of Standards and Appeals, State of Minnesota and can be packaged to meet specific requirements of IRI, FM, GE GAP, NFPA, MIL spec. or other special insurance or local code requirements.

(1) STANDARD UL EQUIPMENT AND IMPORTANT OPTIONS		Gas	No. 2 Oil		No. 4 - 6 Oil Air Atomized	STANDARD UL EQUIPMENT AND IMPORTANT OPTIONS		Gas	No. 2 Oil		No. 4 - 6 Oil Air Atomized
			Pressure Atomized	Air Atomized					Pressure Atomized	Air Atomized	
General	Motor, Fan and Air Inlet Control	X	X	X	X	Gas Fuel	Main Manual Shutoff Valve	X			
	Air Flow Switch	X	X	X	X		Main Safety Shutoff Valve	X			
	(2) Burner Mounted Control Panel, Switch and Four Indicator Lights	X	X	X	X		Second Safety Shutoff Valve	X			
	Flame Safety Control	X	X	X	X		Main Gas Regulator	X			
	Ultra Violet Scanner	X	X	X	X		Gas Checking Valve	X			
	Motor Starter with Overloads	X	X	X	X		High and Low Gas Pressure Switches	X			
	Fuel Selector Switch	Duel Fuel Burners Only					Metering Valve (modulating systems)	X			
Ignition	Proven Gas Pilot Ignition	X		X	X	Oil Fuel	Oil Drawer Assembly with Diffuser		X	X	X
	Pilot Solenoid Gas Valve	X		X	X		Oil Nozzles		X	X	X
	Pilot Gas Regulator & Manual Valve	X		X	X		Oil Heater with Integral Thermostat				X
	Pilot Gas Ignition Transformer	X		X	X		Remote Oil Pump		X	Opt.	Opt.
							Two Safety Shutoff Valves		X	X	X
Options	Inverted Housing	X	X	X	X		High Oil Temperature Switch				X
	Alternate Control Cabinet Positioning	X	X	X	X		Low Air Atomizing Switch				X
	Remote Control Panel	X	X	X	X		Low Oil Pressure Switch		X	X	X
	Fuel Metering CAM-NETIC II	X	X	X	X		Oil Pressure Gauge		X	X	X
	Posi-Control	X	X	X	X		Oil Metering Valve		X	X	X
					Future Gas Combustion Head			Opt.	Opt.	Opt.	
					Air Compressor				X	X	

1. The configuration of each unit will vary with specific job requirements such as input rating, electrical specification and special agency approval codes. The above chart shows those items standard to a basic burner plus a few options that may be added.
 2. Indicator lights are "Power On", "Call for Heat", "Fuel On" and "Flame Fail"

Model JB3 - Sizing and Application Data (contact Webster for complete information)

Model Number	Maximum Furnace Pressure	Burner Firing Capability Range			Burner Motor HP	Gas Train		#2 Oil Pump Motor HP		#4 - 6 Pump Motor HP	Air Compressor Motor HP
		Gas scfh	#2 Oil gph	#4-6 Oil gph		Pipe Size	Inlet Press	Pressure Atomizing	Air Atomizing		
JB3-30	3.5	1400 / 6300	10.2 / 45	10 / 42	3	2 1/2"	12 / 27"	1	Optional	Optional	2
JB3-50	3.5	1400 / 8300	11 / 59.2	10 / 55.3	5	3"	15 / 27"	1 1/2	Optional	Optional	2
JB3-75	3.5	1600 / 10500	12.3 / 75	11 / 70	7 1/2	3"	23 / 27"	1	Optional	Optional	2
JB3-100	3.5	1800 / 12600	20.3 / 90	12 / 84	10	3"	2-5 psi	1	Optional	Optional	2

The above maximum ratings are based on 0 furnace pressure, an altitude of 1000 feet, 90°F air temperature and 60 HZ electrical supply. Use the following corrections for higher temperatures and altitude. Capacity by 17% for 50 Hertz.
 Capacity decreases by 4% for each 1000 feet above 1000 foot altitude.
 Capacity decreases by 6% for each 1 inch of furnace pressure.
 Capacity decreases by 2% for each 10°F increase in air temperature over 90°F.
 Gas input ratings based on 1000 BTU/cu ft. and 0.64 specific gravity. Sizes and pressure will vary with gas.
 Oil input ratings are based on 140,000 BTU/gal. for ASTM #2 fuel oil and 150,000 BTU/gal for ASTM #4-6 fuel oil.
 The vessel draft must be between -0.1 and +0.1 wc.

Essential Ordering Information and Data:

Power Supply - Confirm 120-60-1 for control circuit and electrical supply for burner motor(s) (voltage, frequency and phase).
 Describe Boiler or Heater to be Fired - Including the manufacturer, model number, furnace pressure and furnace size.
 Firing Rate - Define firing rates in MBH for gas and GPH for oil.
 Fuel to be Burned - Type of gas and/or oil, including the BTU value.
 Approval Agency - UL, FM, IRI (GE GAP), CSD-1, NFPA, Mil spec and local codes, if applicable.
 Flame Safety Control Preferred - Honeywell or Fireye controls.
 Gas Train Components Preferred - ASCO/ITT, Honeywell or Landis
 Control System - ON-OFF, Low Fire Start, Low High Low, Modulation, Posi-Control
 Required Options - Mounting plate, operating controls, limit controls, etc.